

Miyano

GN3200

High Precision CNC Lathe

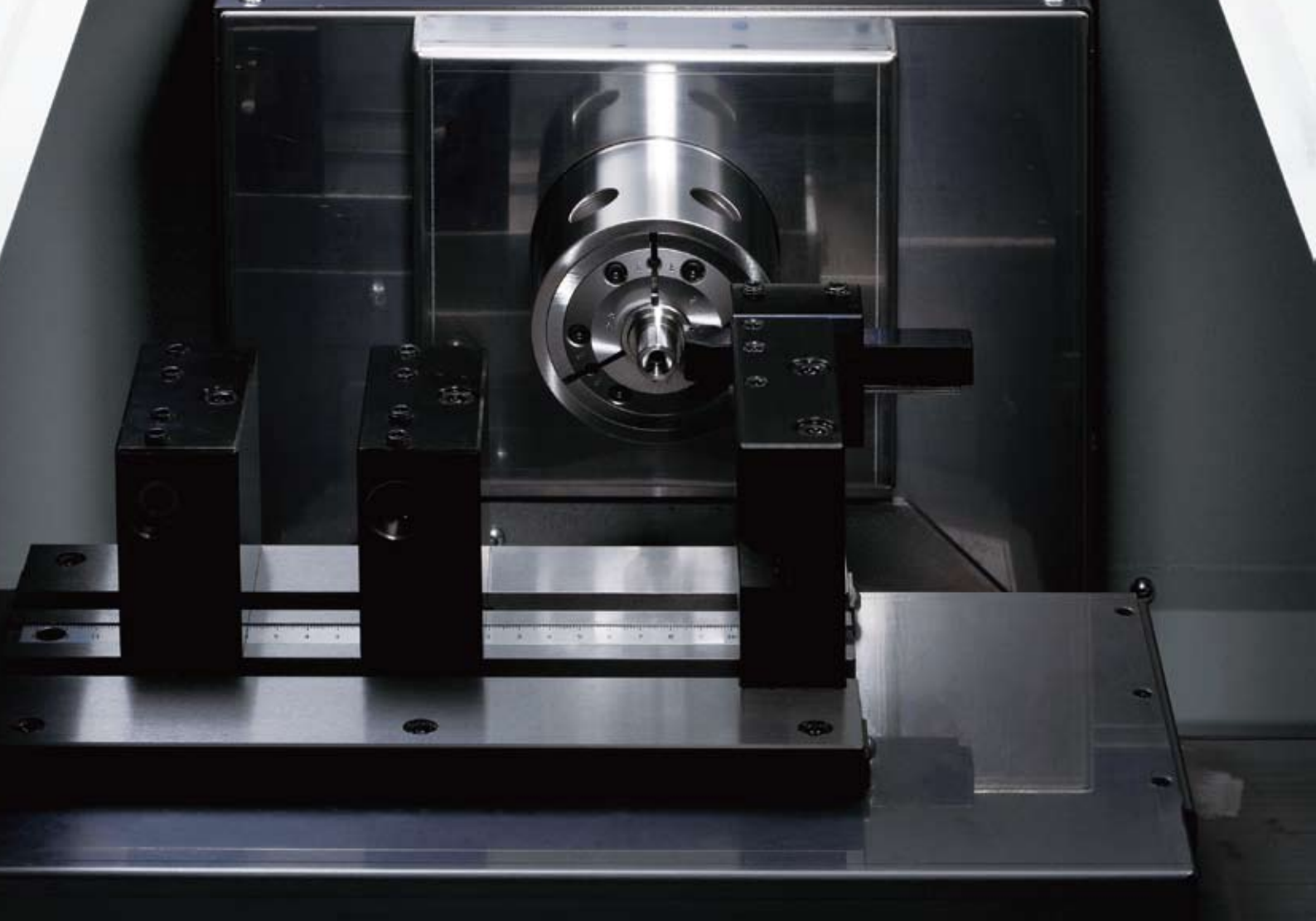



GN3200

High efficiency through space savings

A compact design with a total machine width of 700 mm and a floor space requirement of 1.04 m² has made it possible to shorten production lines and improve factory space utilization.

The incorporation of a high-speed gantry loader with a loading time of 3.5 seconds and a wide choice of infeed and outfeed devices allows stand-alone automation or integration with other processes.

High-precision positioning and exceptional accuracy

A combination of a single slide construction, achieved using slides with excellent damping characteristics and a lubricating oil discharge control has increased follow-up performance for very small axis movement and has brought lost motion as close to zero as possible. Built-in spindles with forced cooling and built-in sensors give smooth rotation with low vibration thanks to beltless drive. This construction ensures outstanding accuracy and repeatability.



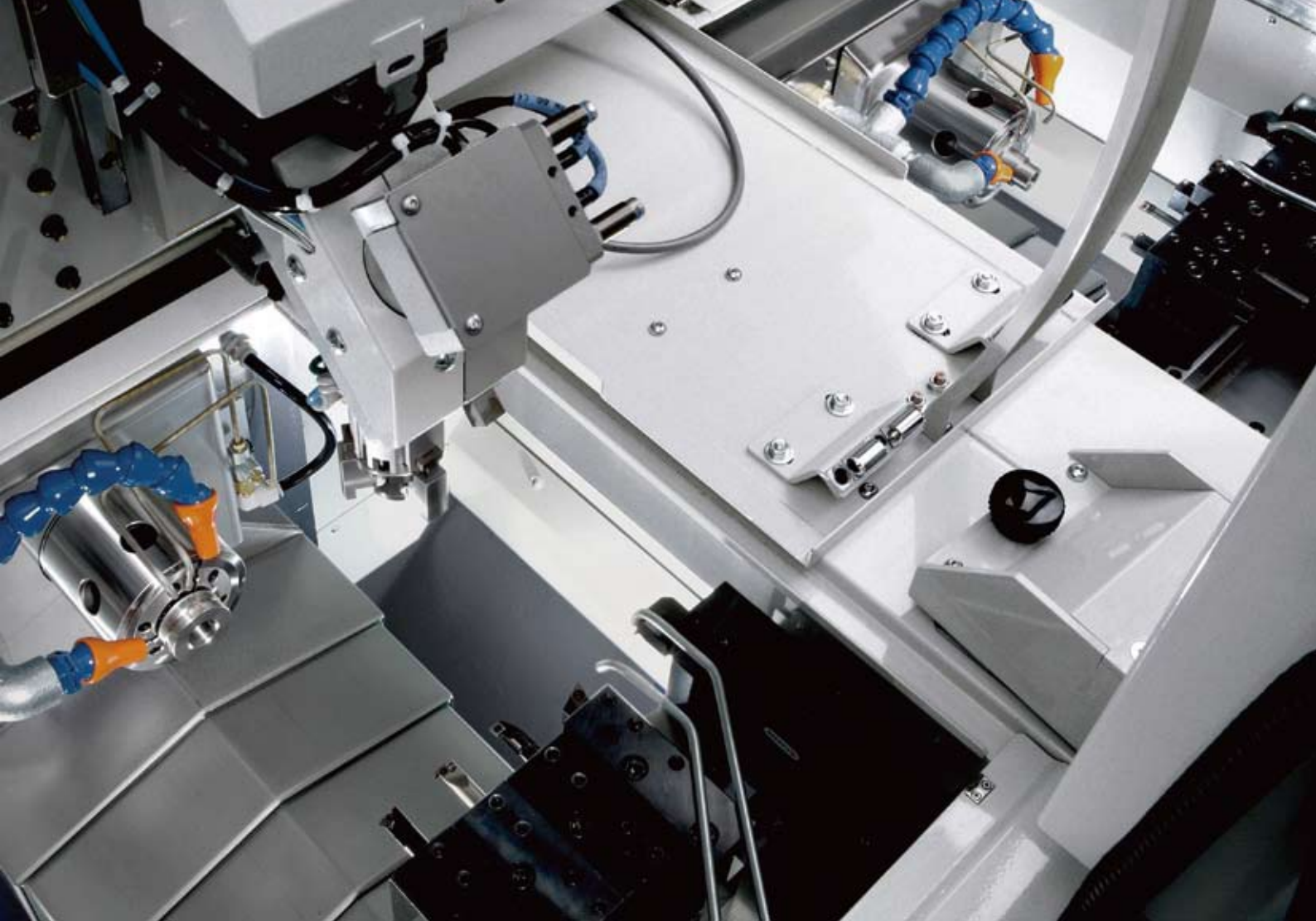

GN3200w

Improved efficiency through further space savings

The GN3200W is the twin spindle version of the GN3200 which, equipped with a high speed loader, makes even higher productivity available. The machine width is 33% shorter than previous Miyano models and the required floor space has been reduced by 27%, realizing significant space saving.

A wide choice of infeed/outfeed devices, single or double high speed gantry loaders, transfer and turnover units makes the machine the best choice to meet specific automation needs.

Clever, rigid construction with zero thermal effect

The basic concept in designing the machine is preventing thermal displacement over time by transferring the heat of machining to the machine body. This is achieved by a frame and bed with a thermally symmetric design, backed up by a wing-type headstock and a separate coolant tank.



Example Configurations

High-efficiency production is achieved in combination with devices like newly designed high-speed gantry loaders featuring excellent cost performance, and part feeders, conveyors and pallet stockers.



Gantry loader with high-speed travel of 154 m/min. on the X axis.

IN conveyor / OUT conveyor

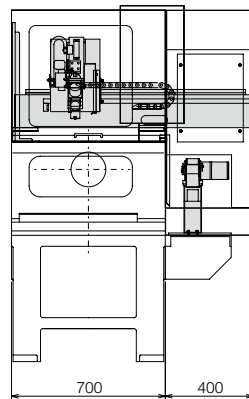
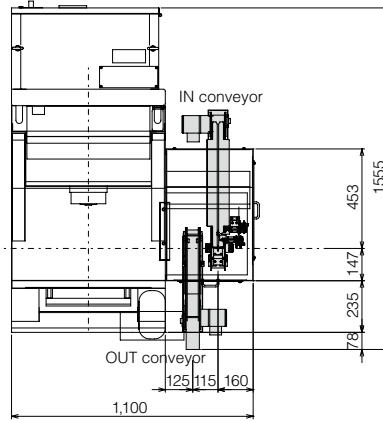

IN part feeder / OUT conveyor

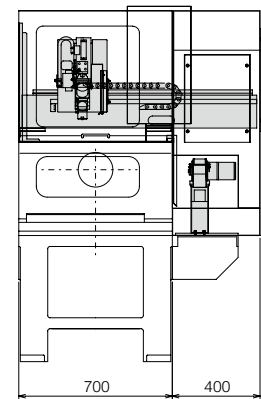
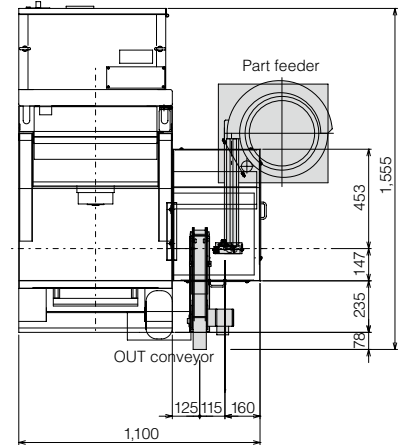

IN/OUT rotary stocker

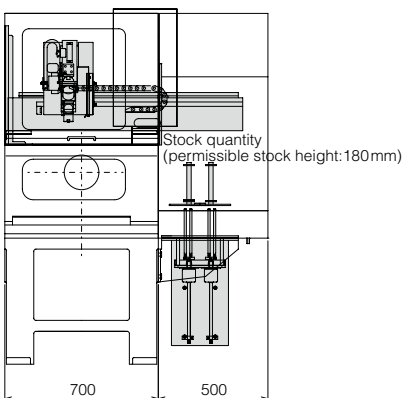
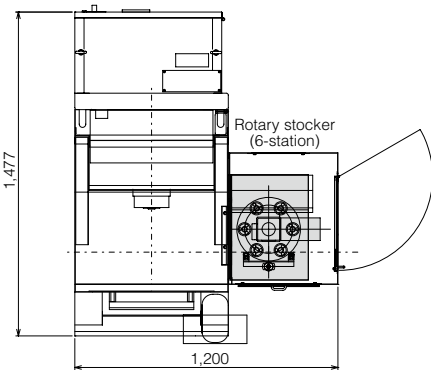

IN/OUT pallet conveyor

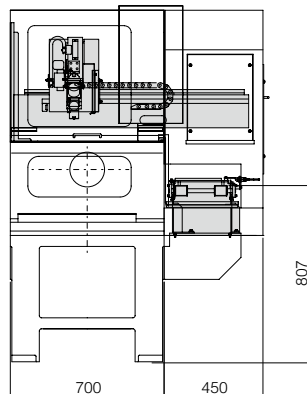
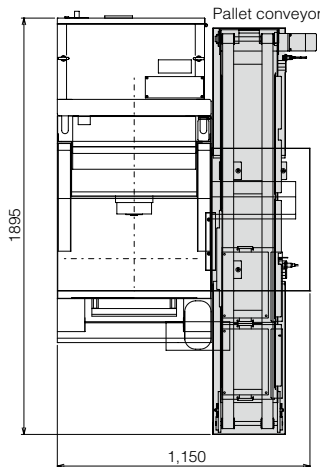

IN/OUT workpiece stocker

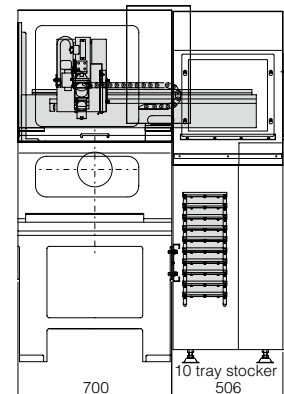
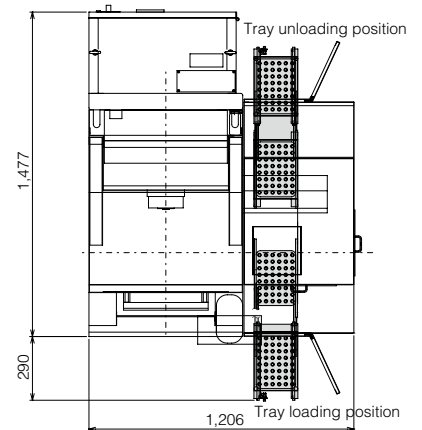

IN conveyor / OUT conveyor

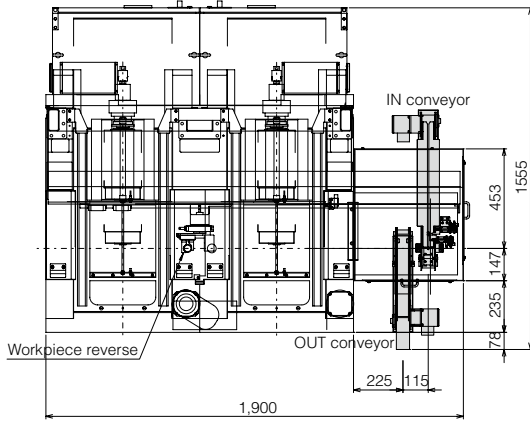

IN part feeder / OUT conveyor

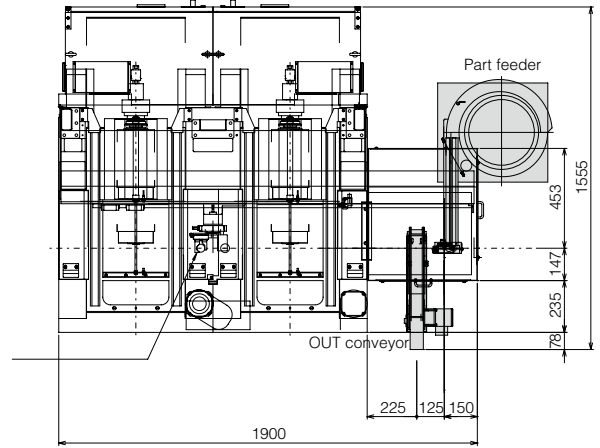

Primary machining Secondary machining

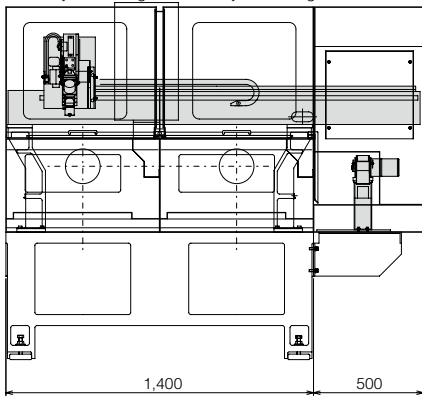

Primary machining Secondary machining

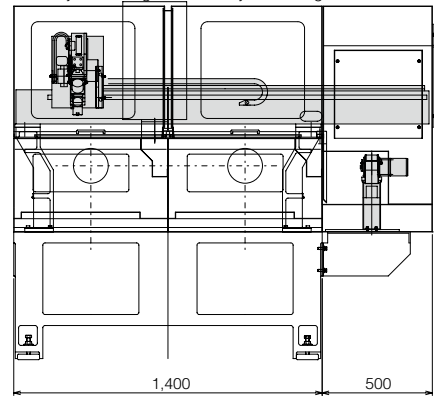

IN pallet conveyor / OUT pallet conveyor

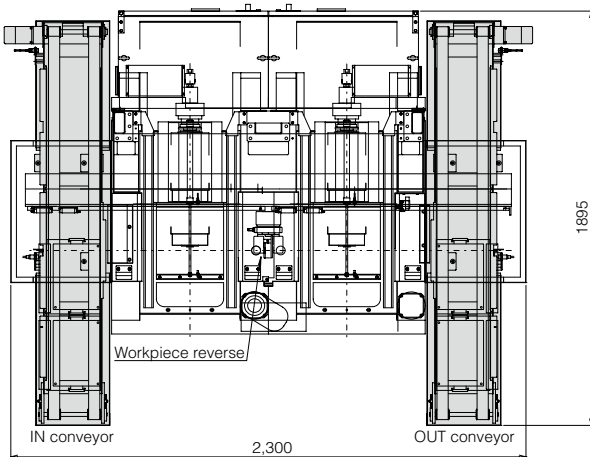

IN workpiece stocker / OUT workpiece stocker

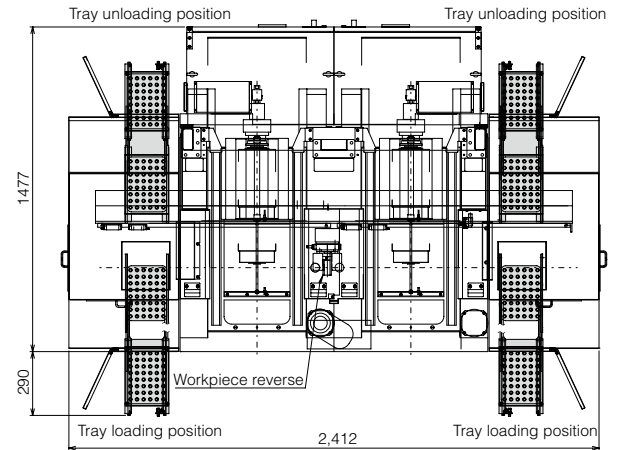

Primary machining Secondary machining

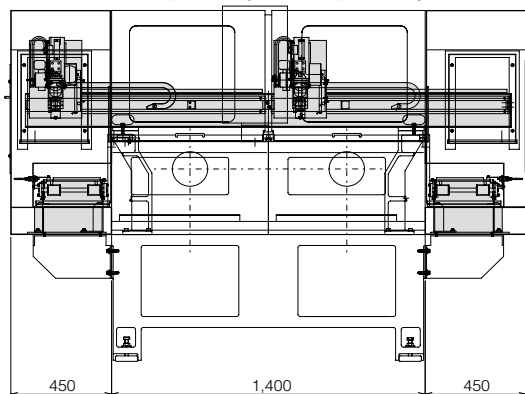

Primary machining Secondary machining

Tray stock quantity: 10 rows

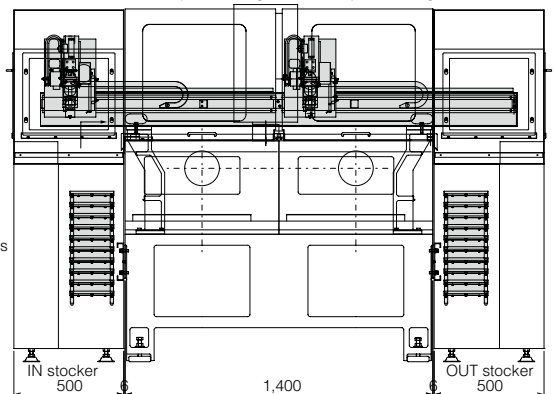

Machining accuracy

Test piece

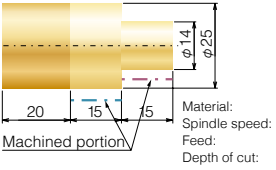

Material: BSBM
 Spindle speed: 2,500m⁻¹
 Feed: 0.05mm/rev
 Depth of cut: 0.1mm

Dimensional accuracy

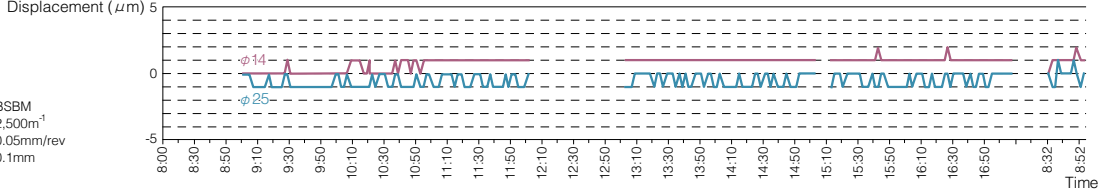

Roundness

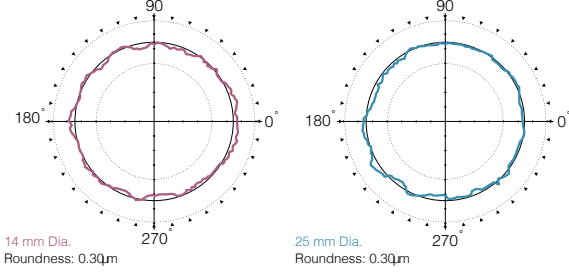

Surface roughness

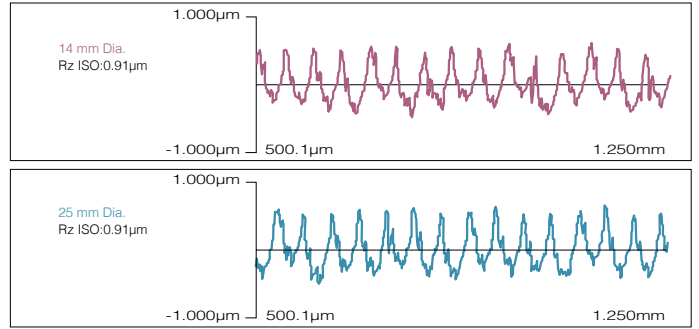

Tooling area

GN3200

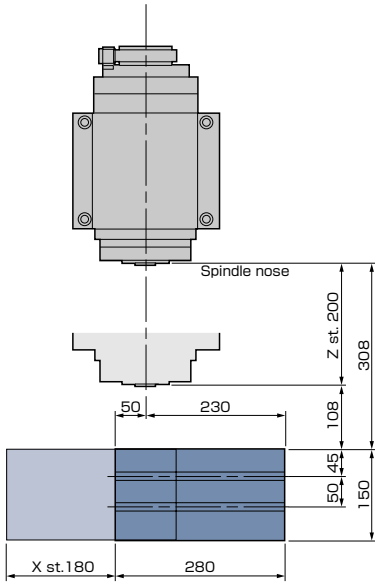

GN3200W

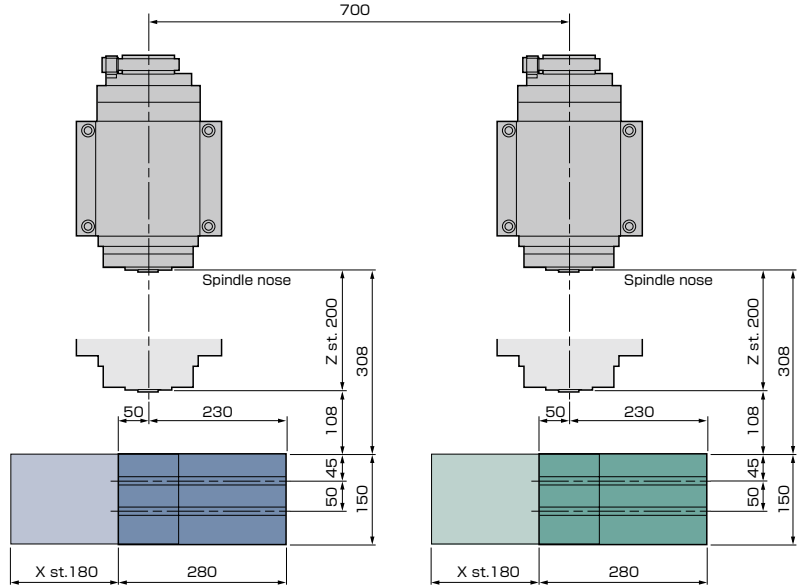

Tooling system

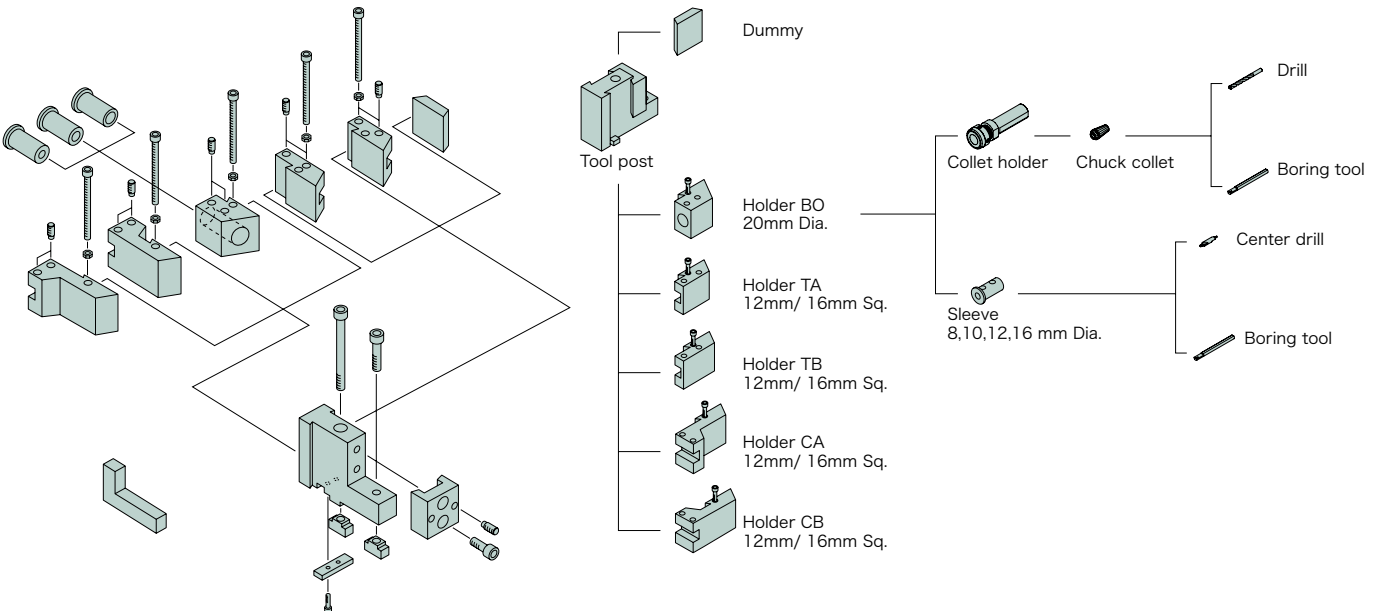

Chuck system

Collet chuck (pull type)



Collet chuck (fixed type)



Fine precision chuck



Power chuck



Diaphragm chuck



External view

GN3200

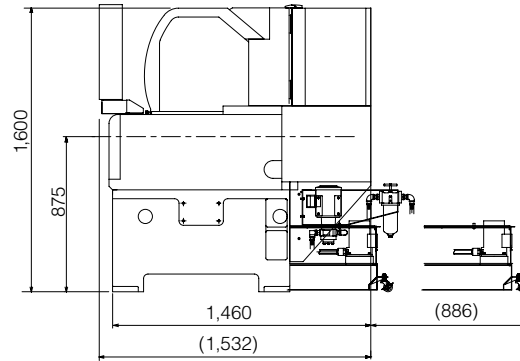
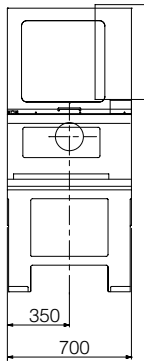

GN3200W

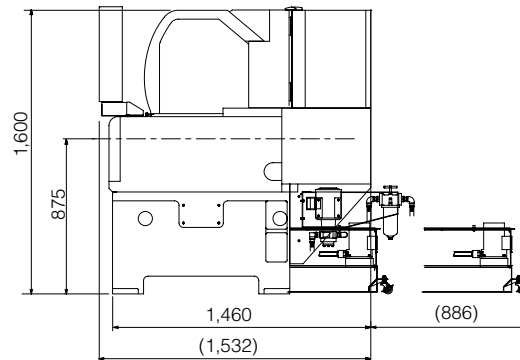
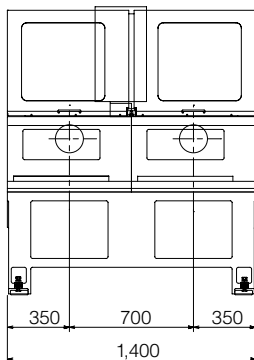

NC Specification

GN-3200	FS 0i-TD 1 system
Controlled axis	X, Z
Min. input increment	0.0001mm, 0.00001inch, 0.0001deg
Min. output increment	X axis:0.00005mm (Radius value) Z axis:0.0001mm
Interpolation	G01, G02, G03
Threading	G32, G33, G34
Rapid feed override	0 - 100%
Cutting feed override	0 - 150%
Parts program storage capacity	512Kbyte(1,280m)
No of registered programs	400
Spindle function	Spindle speed S4-digits, directly specified (G97), Constant Cutting speed control (G96)
Tool function	T ##** (## = Tool number & geometry, ** = Wear offset number)
Tool compensation	64 pieces (total of 3 system: 96 pieces)
Data input/output	RS-232C, Memory card interface
Others	8.4" color LCD, Work piece coordinate system (G52 - G59), Inch/metric change, Chamferring/Corner R, Programmable data input (G10), Direct drawing dimension programming, Drilling canned cycle, Custom macro, Multiple repetitive canned cycle, Background editing, Spindle orientation, Rigid tapping, Tool life management, Tool nose R compensation(G40, G41, G42), Actual cutting feed rate display, Operating time/Parts No. display.
Options	Polar coordinate interpolation, Cylindrical interpolation, Cs outline control.

GN-3200W	FS 0i-TD 2 system
Controlled axis	X, Z 2 axes x 2 systems
	2 Saddle loader: 2 axes x 2 systems 1 Saddle loader: 2 axes x 1 system
Min. input increment	0.0001mm, 0.00001inch, 0.0001deg
Min. output increment	X axis:0.00005mm (Radius value) Z axis:0.0001mm
Interpolation	G01, G02, G03
Threading	G32, G33, G34
Rapid feed override	0 - 100%
Cutting feed override	0 - 150%
Parts program storage capacity	Total of 2 systems 1Mb (2,560m)
No of registered programs	800 (Total of 2 systems)
Spindle function	Spindle speed S4-digits, directly specified (G97), Constant Cutting speed control (G96)
Tool function	T ##** (## = Tool number & geometry, ** = Wear offset number)
Tool compensation	64 pieces (total of 3 system: 96 pieces)
Data input/output	RS-232C, Memory card interface
Others	8.4" color LCD, Work piece coordinate system (G52 - G59), Inch/metric change, Chamferring/Corner R, Programmable data input (G10), Direct drawing dimension programming, Drilling canned cycle, Custom macro, Multiple repetitive canned cycle, Background editing, Spindle orientation, Rigid tapping, Tool life management, Tool nose R compensation(G40, G41, G42), Actual cutting feed rate display, Operating time/Parts No. display.
Options	Polar coordinate interpolation, Cylindrical interpolation, Cs outline control.

Machine specifications

Items		GN-3200	GN-3200W
Machining capacity			
Max. Diameter of chuck		Pull type collet chuck	40 mm Dia.
		fixed type collet chuck	35 mm Dia.
		Fine precision air chuck	45 mm Dia.
		Power chuck	45 mm Dia.
		Diaphragm chuck	45 mm Dia.
Max. Machining length		50 mm Dia.	
Max. work length with loader		40 mm Dia.	
Spindle			
Number of spindles		1	2
Spindle nose		Special flat	
Through hole diameter		17 mm Dia.	
Inner diameter of draw tube		11 mm Dia.	
Spindle speed range		8,000 min ⁻¹	
Slide			
Number of Tool Platens		1	2
Type		Horizontal linear tool platen	
Type of slide	X-axis	Dovetail	
	Z-axis	Dovetail	
Control axis		2-Axis (Simultaneously X, Z)	2x2-Axis (Simultaneously X, Z)
Slide travel	X-axis	180mm	
	Z-axis	200mm	
Rapid feed rate	X-axis	15m/min	
	Z-axis	15m/min	
Tools			
Shank size of square turning tool		10, 12, (16) mm Sq.	
Number of tools	Standard	5	5x2
Diameter of drill shank		20 mm Dia.	
Motor			
Spindle drive	15Min./ Cont.	2.2/1.5kw	
Coolant			
Tank type		Separate type	
Tank capacity		90 L	200 L
Spindle Cooling device			
Tank capacity	Oil Viscosity VG10	7 L	9 L
Air supply			
Air pressure supply		0.4 Mpa (4kgf/cm ²)	
Lubricating system			
Tank capacity	Oil Viscosity VG32	1.5 L	1.5 Lx2
Equipment power supply			
Capacity		7.2 KVA	14 KVA
Machine dimensions			
Spindle center height		875 mm	
Machine height		1,600 mm	
Floor space	Width	700 mm	
	Depth	1,460 mm	
Machine weight		1,500 kg	2,700 kg
Others			
Spalsh guard interlock.			
Optional accessories			
Gantry loader, Chuck Systems, Air Blow, High pressure & inner coolant, Spindle inner coolant, Automatic fire-extinguisher, Automatic power off, Chip conveyor, Chip box, Total and Preset Counter, Total and multi counter, Coolant mist collector duct, Damper & duct, warning light, Specification color, etc.			

Loader specifications (Optional)	2-Axes NC	1 saddle 2 hands	1 saddle 2 hands
		---	2 saddles 4 hands
Conveyance capability			
Max. work piece size		40x 40 mm Dia.	
Max. weight capacity		250g	
Feed rate	Right and left operation	130 m/ min	
	Upper and lower sides	154 m/ min	
Control			
Control system		PMC axis control	
Control soft		Flexible loader control	
Drive system	Right and left operation	Rack & pinion	
	Upper and lower sides	Rack & pinion	

CITIZEN MACHINERY CO.,LTD.



JAPAN	CITIZEN MACHINERY CO.,LTD. 4107-6 Miyota, Miyota-machi, Kitasaku-gun, Nagano-ken, 389-0206, JAPAN	TEL.81-267-32-5901	FAX.81-267-32-5908
SOUTH ASIA	CINCOM MIYANO ASIA SALES CO.,LTD. 1230 Rama 9 Road, Kwang Suanluang, Khet Suanuang, Bangkok 10250 THAILAND	TEL.66-23-745-226	FAX.66-23-745-228
KOREA	CINCOM MIYANO KOREA CO.,LTD. Room No.105 BYUCKSAN DIGITAL VALLEY I 212-16, Guro-3dong, Guro-gu, Seoul, KOREA	TEL.82-70-4337-1325	FAX.82-70-8220-8539
TAIWAN	CINCOM MIYANO TAIWAN CO.,LTD. 10FL., No.174, Fuh Sing N. Rd., Taipei, TAIWAN	TEL.886-2-2715-0598	FAX.886-2-2718-3133
CHINA	CITIZEN (CHINA) PRECISION MACHINERY CO.,LTD. 10058, XINHUA ROAD OF ZHOUCUN, ZIBO, SHANDONG, P.R. CHINA	TEL.86-533-6150560	FAX.86-533-6161379
EUROPE-Germany	CITIZEN MACHINERY EUROPE GmbH Mettinger Strasse 11, D-73728 Esslingen, GERMANY	TEL.49-711-3906-100	FAX.49-711-3906-106
EUROPE-UK	CITIZEN MACHINERY UK LTD 1 Park Avenue, Bushey, WD23 2DA, UK	TEL.44-1923-691500	FAX.44-1923-691599
AMERICA	MARUBENI CITIZEN-CINCOM INC. 40 Boroline Road Allendale, NJ 07401, U.S.A.	TEL.1-201-818-0100	FAX.1-201-818-1877

URL:<http://cmj.citizen.co.jp/>

All specifications are subject to change without prior notice. This product is an export control item subject to the foreign exchange and foreign trade act. Thus, before exporting this product, or taking it overseas, contact your CITIZEN machine dealer. Please inform your CITIZEN machine dealer in advance of your intention to re-sell, export or relocate this product. For the avoidance of doubt products includes whole or part, replica or copy, technologies and software. In the event of export, proof of approval to export by government or regulatory authority must be evidenced to CITIZEN. You can operate the machines after the confirmation of CITIZEN. CITIZEN is a registered trademark of Citizen Holdings Co., Japan.